

Model TPD80180A3

Features

Excellent phase & amplitude balance
 Low Insertion Loss & VSWR
 High Isolation

Technical Data Sheet			
Frequency Range	8~18GHz	Finish	Painted Blue_ RAL #5007
Insertion Loss	≤0.8dB (Above 4.77dB Split)	Connector Body	Passivated Stainless Steel
VSWR	Input ≤1.50:1 Output ≤1.50:1	Housing	Aluminum, 6061 T6 Clear Chem Conversion Film
Isolation	≥18dB	Connector Pin	Beryllium Copper, Gold Plate
Amplitude Balance	≤±0.6dB	Solder	Lead Free, RoHS Compliant
Phase Balance	≤±6°	Operating Temperature	-55~+85°C
¹ Power Handling	Forward ≤30Watt; Reversed ≤1Watt	Operating Humidity	Up to 95%, Non-Condensing
Impedance	50Ω	Weight	30g
Port Connectors	SMA-Female		

¹Power Handling guaranteed when load's VSWR within 1.50:1.

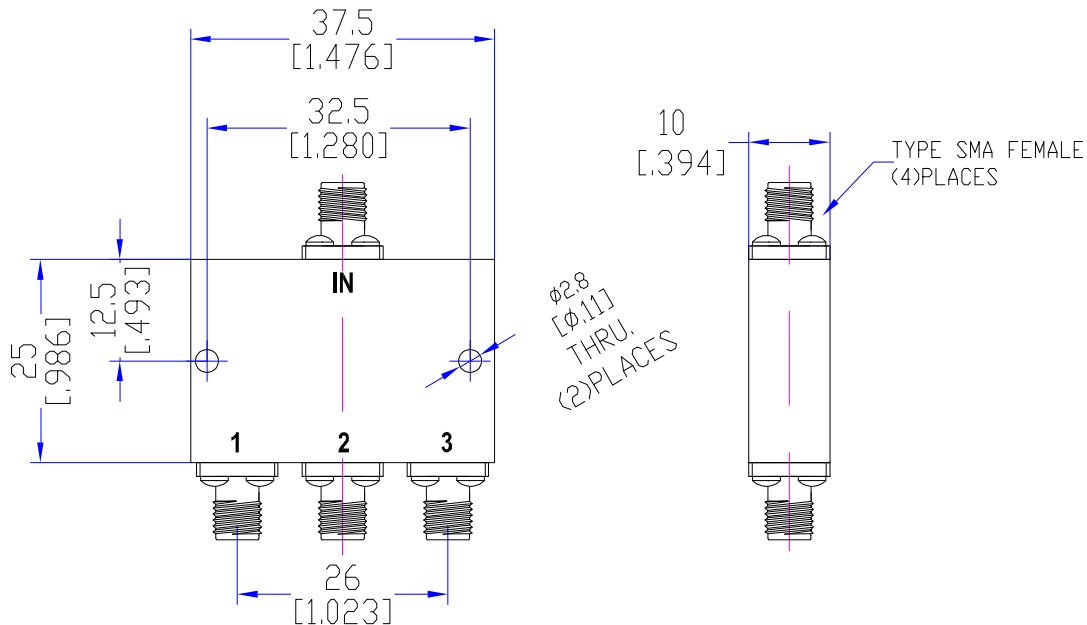

Typical Performance

1. Insertion Loss, Amplitude & Phase Balance, VSWR

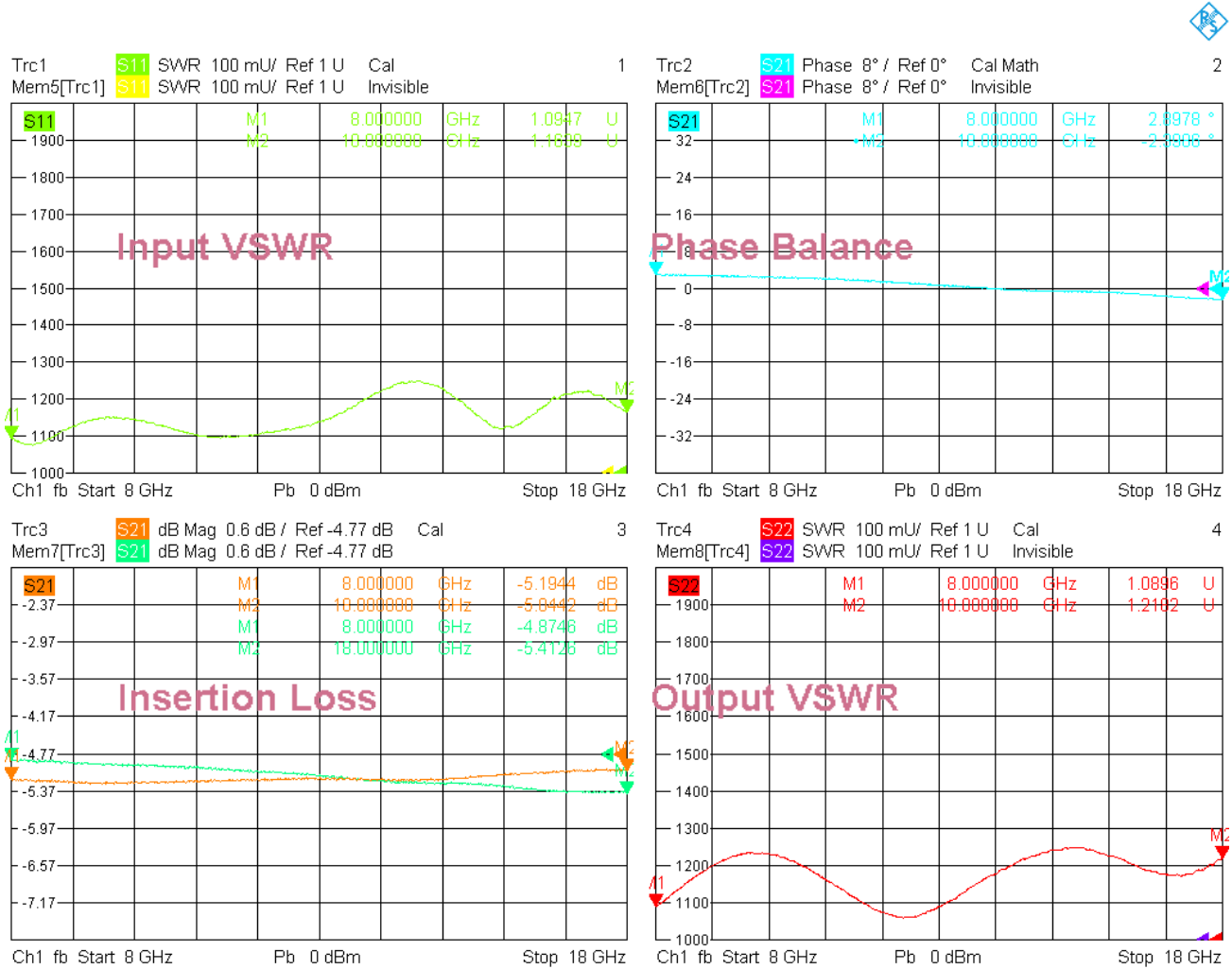

10/26/2021, 3:51 PM



Typical Performance

2. Insertion Loss, Amplitude & Phase Balance, VSWR

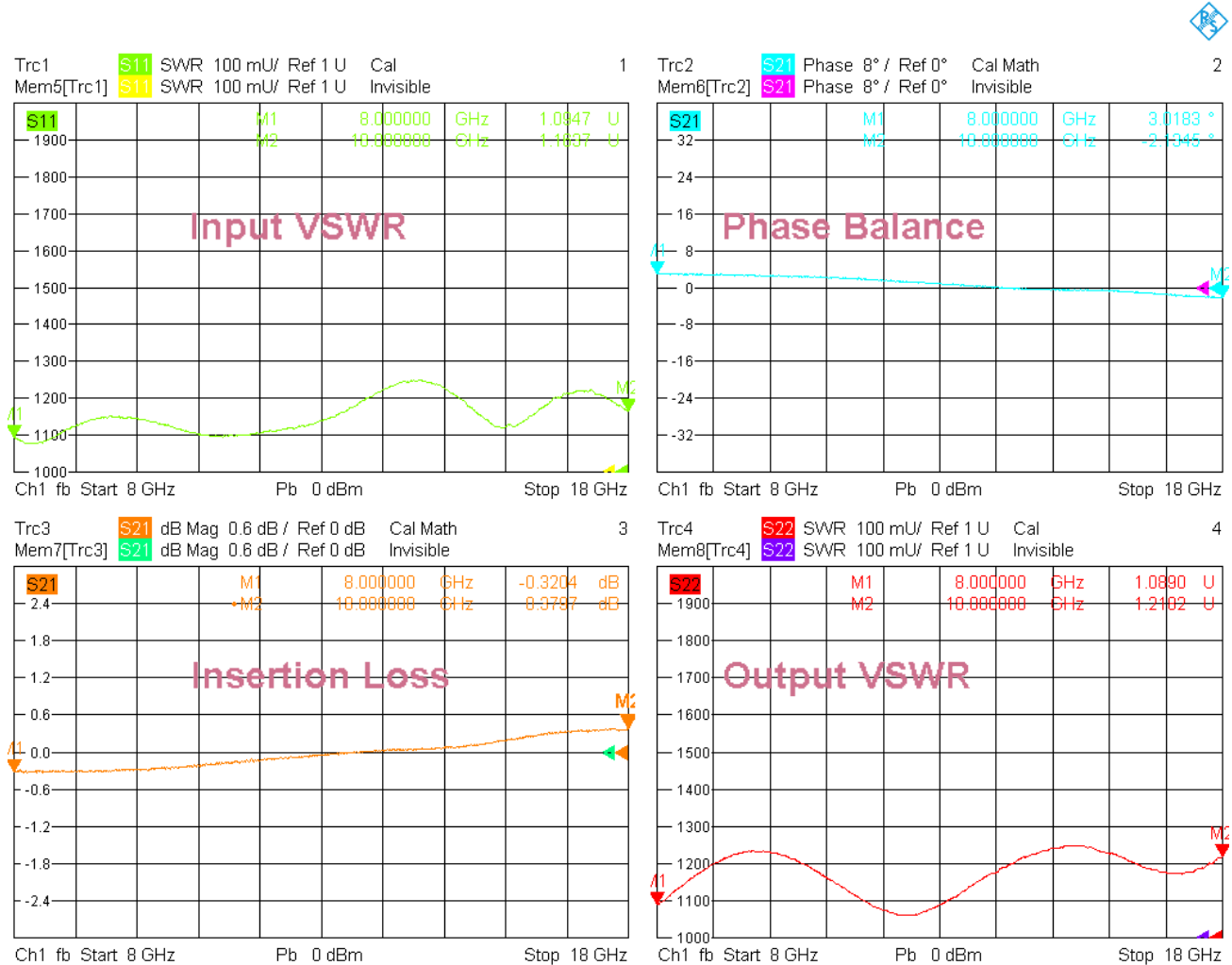

10/26/2021, 3:51 PM

3. Isolation

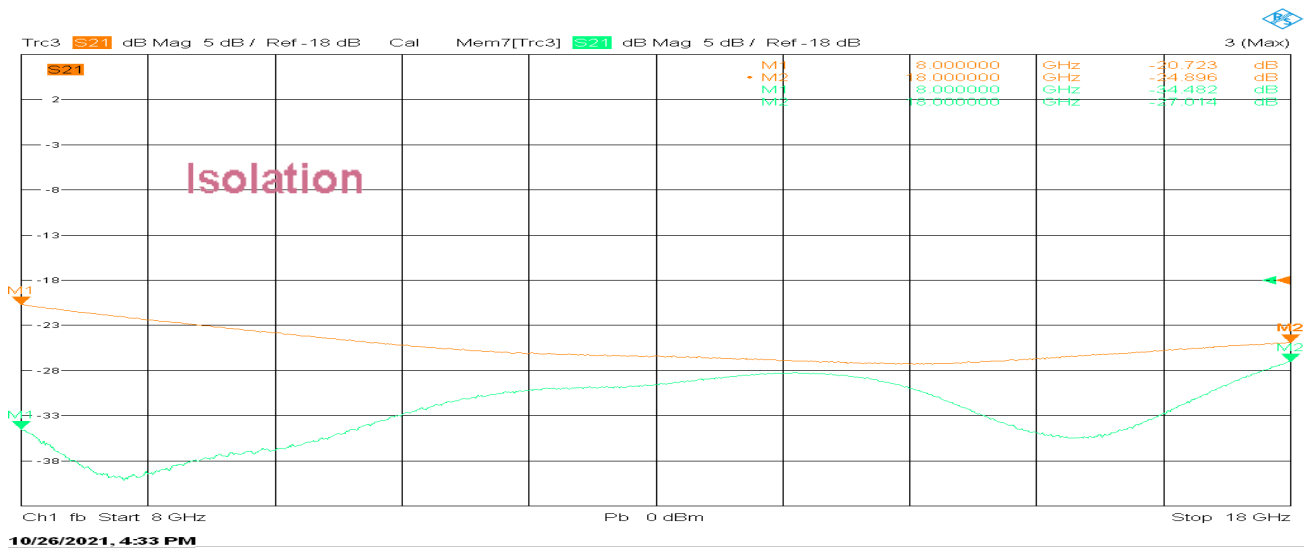

10/26/2021, 4:33 PM

