

Model TPD50400A4

Features

- Excellent phase& amplitude balance
- Low Insertion Loss& VSWR
- High Isolation

| Technical Data Sheet | | | |
|-----------------------------|-------------------------------------|-----------------------|---|
| Frequency Range | 5~40GHz | Finish | Painted Blue_ RAL #5007 |
| Insertion Loss | ≤3.3dB (Above 6.02dB Split) | Connector Body | Passivated Stainless Steel |
| VSWR | Input ≤1.60:1 Output ≤1.60:1 | Housing | Aluminum, 6061 T6 Clear Chem Conversion Film |
| Isolation | ≥15dB | Connector Pin | Beryllium Copper, Gold Plate |
| Amplitude Balance | ≤±0.5dB | Solder | Lead Free, RoHS Compliant |
| Phase Balance | ≤±6° | Operating Temperature | -55~+85°C |
| ¹ Power Handling | Forward ≤10Watt; Reversed ≤1Watt | Operating Humidity | Up to 95%,Non- Condensing |
| Impedance | 50Ω | Weight | 50g |
| Port Connectors | 2.92mm-Female | | |

¹Power Handling guaranteed when load's VSWR within 1.50:1.

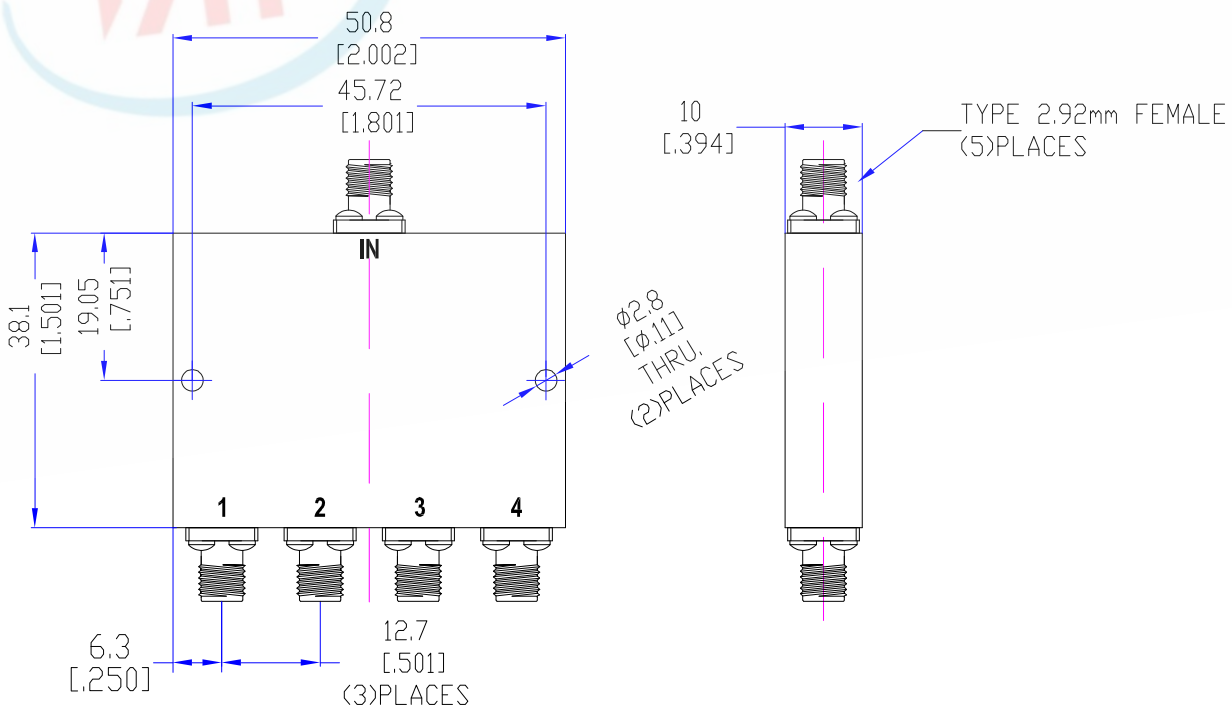

Typical Performance

1. Insertion Loss, Amplitude & Phase Balance, VSWR

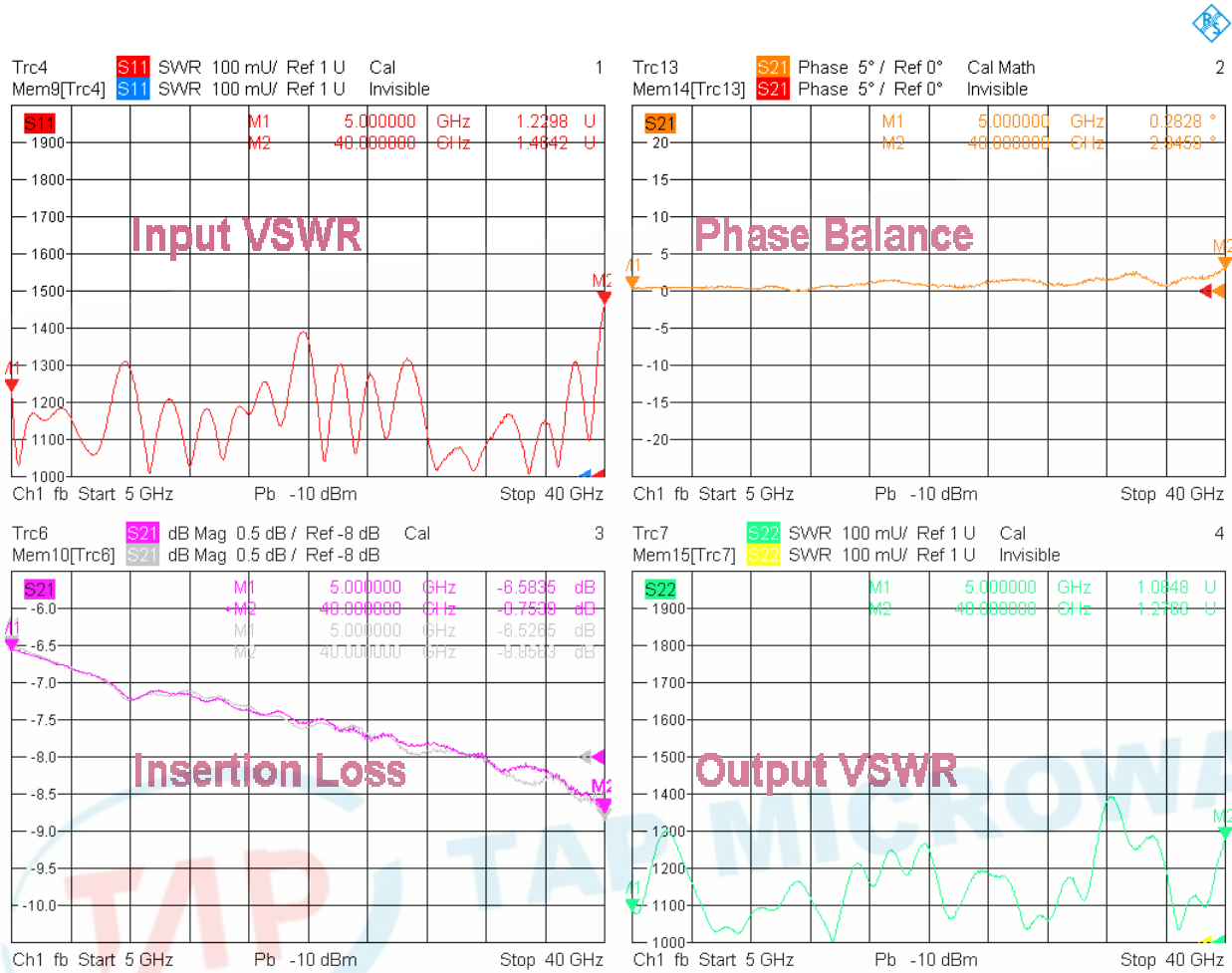

2/24/2023, 12:25 PM

2. Isolation

